

LEWIS & PROSAFE

Handguards Mounting Instructions

Exploded View

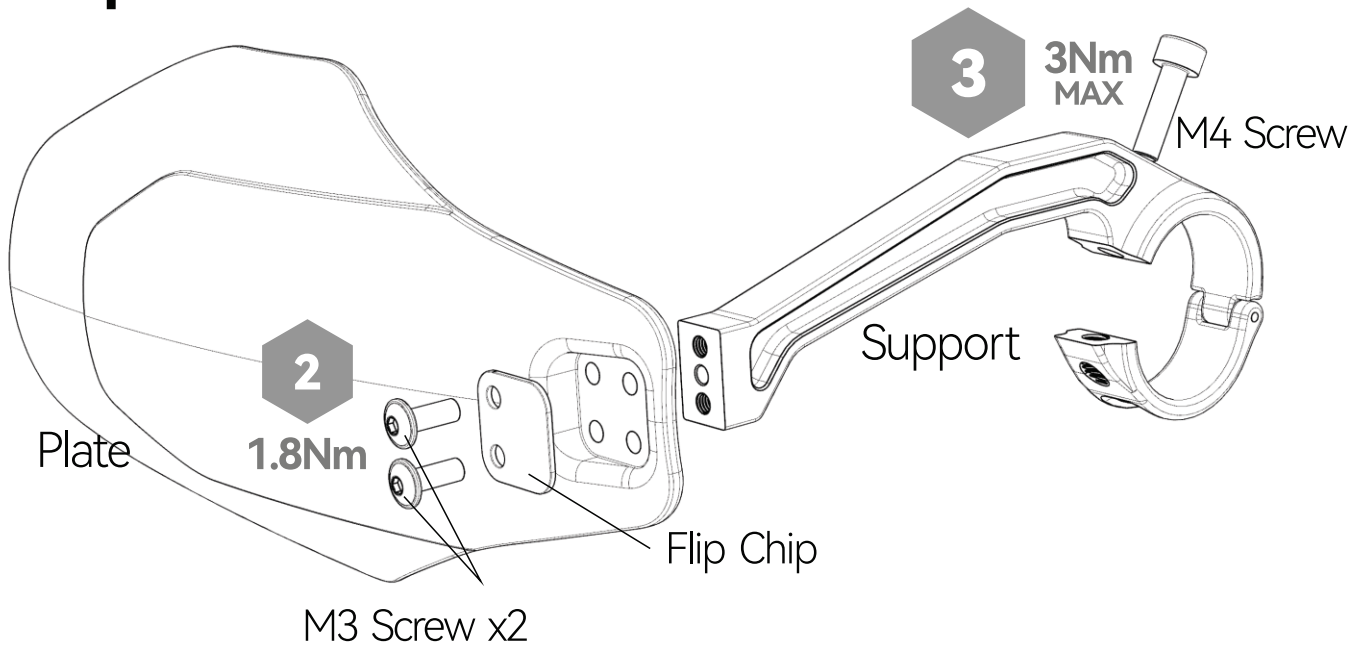

For optimum protection it is recommended that the **support be mounted horizontally to minus 10° from the ground.**

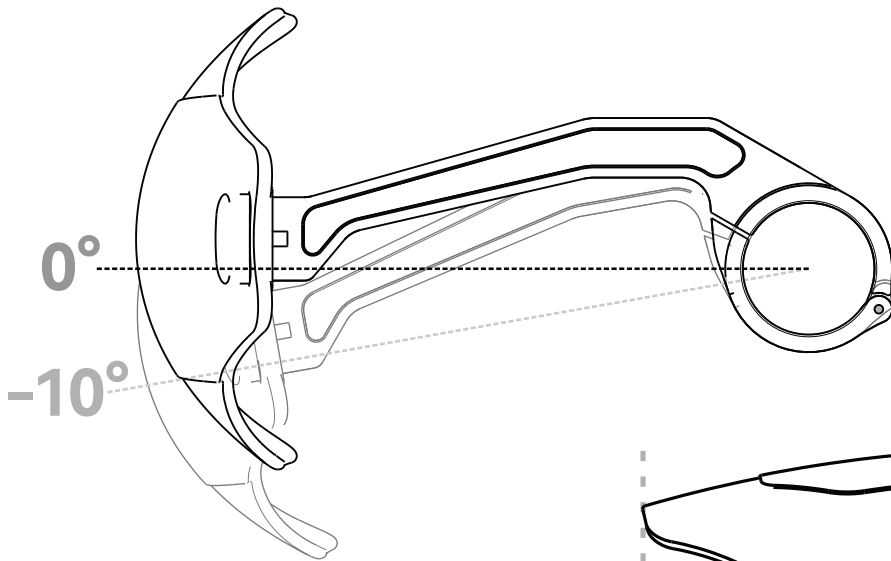

Due to the fact that most MTB handlebar on the market are designed to float backward, the **Support needs to be mounted close to the grips** in order to achieve the best protection and the lowest wind resistance for the hands.

